

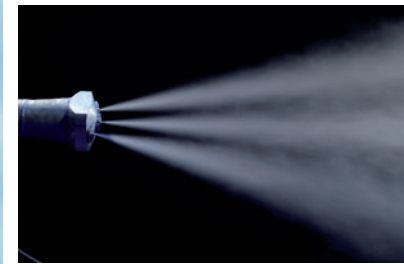

VarioClean - NO_x

Nozzle lances and systems
for gas denitrification

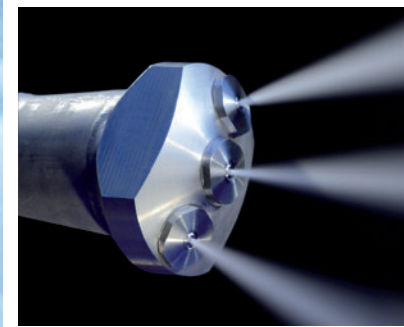

SCR/SNCR
SCR/SNCR

LECHLER NOZZLE LANCES AND SYSTEMS FOR PERFECTING YOUR DENITRIFICATION

Lechler is one of the world's leading nozzle technology companies.

In the more than 130 years of our company's history, we have



developed know-how that brings you - the user - tangible advantages.



For denitrification technology, Lechler supplies advanced and practical nozzle lances and systems in unbeatable quality, and provides support from a team of experienced specialists.

Nitrogen oxide emissions must be reduced

For industrial furnaces and combustion plants, the limit values for nitrogen oxide emissions have been increasingly tightened up in recent years. In addition to the combustion-related primary measures, such as gradation of the combustion air and flue gas circulation, great importance is also attached to reducing the nitrogen oxides by injecting in denitrification agents.

Without these secondary measures, it would be difficult to achieve the limit values in force today. In these processes, selectively-acting reducing agents such as ammonia water or urea are usually injected into the flue gas. The success of this process is to a great extent dependent on perfecting the nozzle technology employed.

CFD simulation provides reliability in project planning

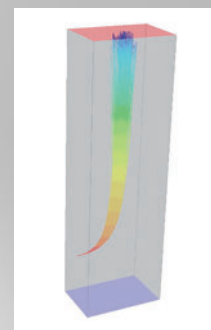

Droplet trajectories and changes to the droplet diameter after the denitrification agent has been injected.

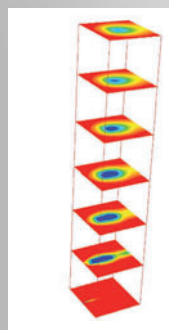

Temperature curve at various levels after the denitrification agent has been injected.

MS ION PROCESSES



Lechler – your competent partner in this specialist field

The complexity of the task and the stringent technical requirements come with many risks. Choose Lechler and you can be sure of unsurpassed know-how and perfect technology.

What this means for you:

- Greater efficiency thanks to optimum process-related design aided by state-of-the-art CFD simulation.
- Precise measurement data on the nozzles' spray characteristic are available for your own CFD calculations.
- Design, delivery, commissioning and service all from a single source.
- Reliable spare parts supply throughout the world.

SNCR

SNCR process

The SNCR process is often used in refuse incineration plants, the cement industry and power stations. Here, the optimum temperature range in which the nitrogen oxides are reduced at a favourable rate is approximately 900 to 1000 °C.

In addition to the temperature, the correct droplet spectrum is also of particular importance for ensuring that the process runs optimally: The droplets must be sufficiently large so that they penetrate sufficiently deep into the flue gas flow and nevertheless still evaporate reliably. The most even distribution possible of the reducing agent in the flue gas flow is also important.

Lechler twin-fluid flat spray nozzles meet these requirements convincingly. Their high pulse rate and the deep, flat coverage of their spray pattern allow optimum mass transfer between the reducing agent and the flue gas flow.

As they are easily controllable, twin-fluid nozzles are optimally suited for the greatly fluctuating NO_x concentrations in cement works and refuse incineration plants.

SCR

SCR process

The SCR process with injection is used mainly in power stations, but also in refuse incineration and the glass industry. This involves injecting the reducing agent

upstream of the catalyst, whereby it must be distributed in the flue gas flow as homogeneously as possible and evaporated very quickly.

In practice, static mixers that mix gas and the reducing agent are often used in addition to the nozzles. This allows extremely short evaporation paths at a low temperature level of approximately 300 to 400 °C.

It must be guaranteed that the reducing agent is completely evaporated before it reaches the catalyst. To make sure of this, Lechler has developed twin-fluid nozzles that meet these requirements superbly by virtue of their extremely fine droplet spectrum and their precise controllability, and that have proved extremely successful when used in large power stations.

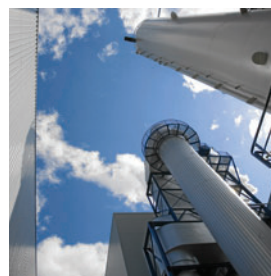

LECHLER PRODUCTS PROVE THEMSELVES IN MANY APPLICATIONS

Cement / calcinator – SNCR

Cement / calcinator – SNCR

SNCR process in a cement works calcinator.

- Optimum mass transfer between the reducing agent and flue gas, e.g. via twin-fluid flat spray nozzles.

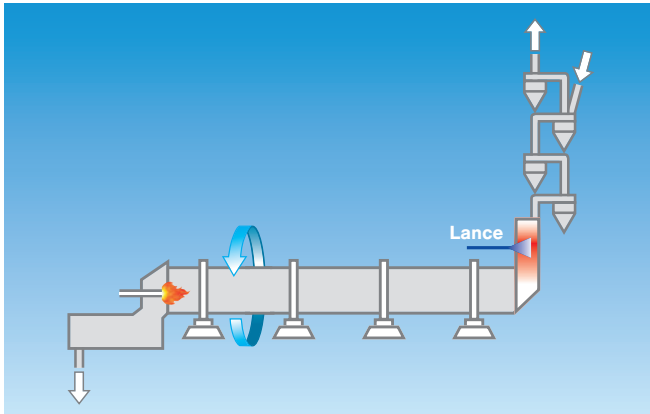

Refuse incineration – SNCR

Refuse incineration SNCR

SNCR process in refuse incineration plants.

- Very good controllability of droplet size / pulse rate so that fluctuating NO_x concentrations can be counteracted.

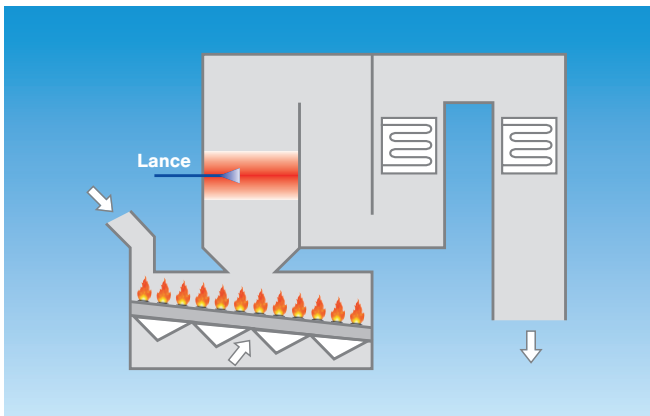

Cement / long kiln – SNCR

Cement / long kiln – SNCR

SNCR process in the long cylindrical rotary kilns of cement works.

- Process for denitrification directly in the kiln, including media routing along the rotary kiln.

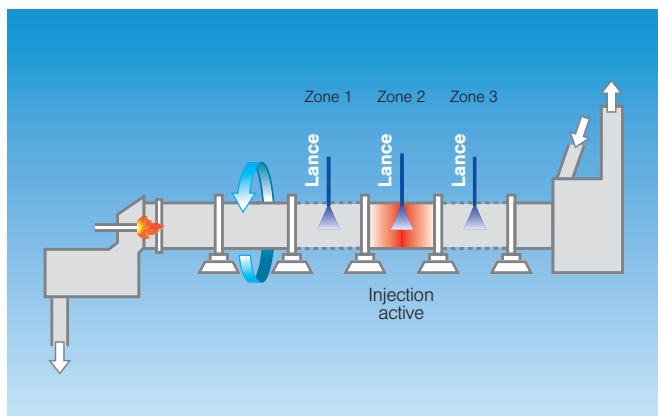

Large power station – SCR

Large power station – SCR

SCR process in large power stations.

- New nozzle technology for very short evaporation paths (patent pending).

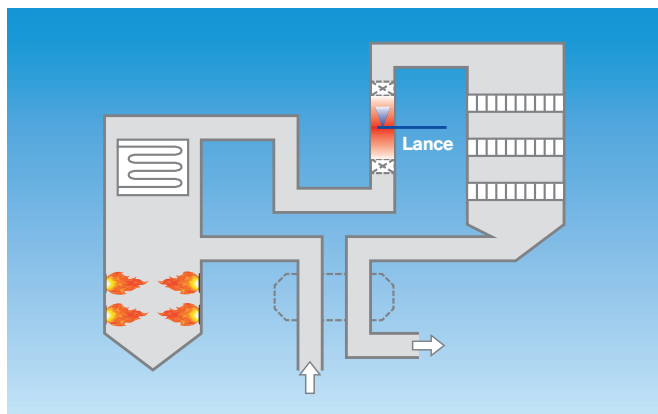

LECHLER NOZZLE TECHNOLOGY FOR

Lechler nozzles for gas denitrification are the result of many years of research and development work. Taking our specialist knowledge from nozzle technology as the basis, this has seen the development of special solutions for use in SNCR and SCR plants. State-of-the-art design, simulation and measuring technology ensures in advance that the results will meet your requirements exactly. Automated production processes guarantee maximum precision.

Lechler nozzles for SNCR systems

Lechler twin-fluid nozzles for SNCR plants atomize on the basis of the internal mixing principle. Changing the air/liquid ratio allows the droplet spectrum and the pulse rate to be adapted to the droplets. A robust design and the correct choice of materials allow use even at high temperatures.

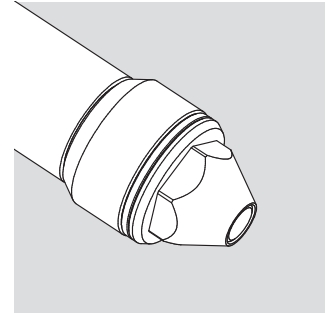

Lechler twin-fluid flat spray nozzles add to these properties with even better, complete coverage.

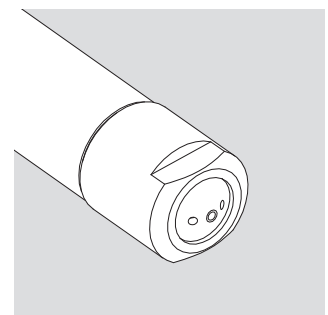

Lechler twin-fluid nozzles for SCR plants operate on the principle of a newly developed atomization principle for which the patent is pending.

This allows very fine droplet spectrums and extremely short evaporation paths to be realised together with very good controllability of the flow rate.

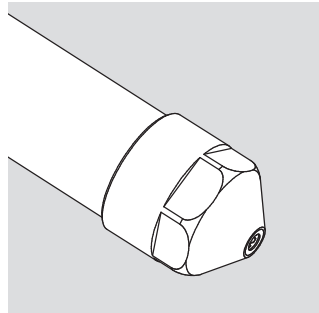

Cluster heads designed specially for these nozzles allow multiplication of the flow rates and adaptation of the spray pattern to the requirements at the injection location, e.g. upstream or downstream of static mixers.

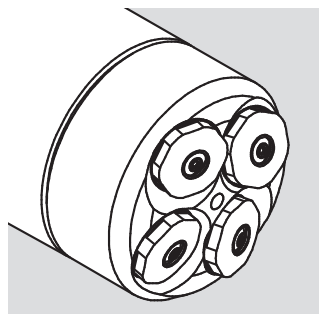
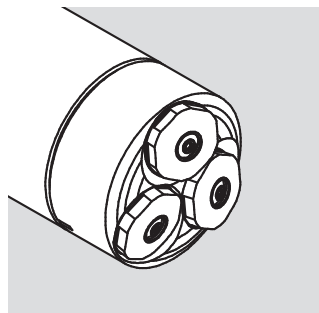
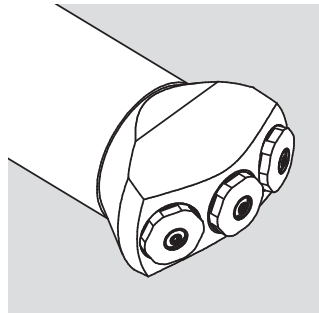

LECHLER NOZZLE LANCES

Lechler nozzle lances tailored exactly to your tasks

Lechler nozzle lances tailored exactly to your tasks ensure optimum placement and alignment of the spray pattern in the flue gas duct. They are therefore adapted precisely to the particular denitrification process and the individual local requirements – another reason for the high functional reliability of the

Lechler technology. In practice, different design variants and special accessory parts often open up completely new possibilities. The following are a few examples of this:

- Protective tubes with barrier air connection.
- Assembly connecting pieces with flange

connection for sealing into the flue gas duct.

- Compensators for equalising different elongations.
- Adjustable lance length.
- Accessory sets for the media connection.

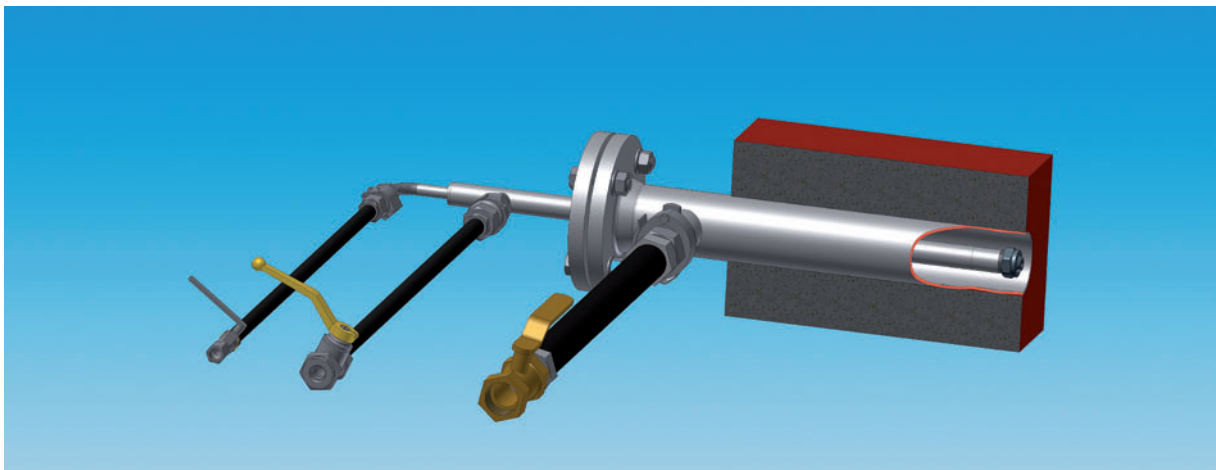

Nozzle lance for SNCR applications (for installation in the wall of the gas duct)

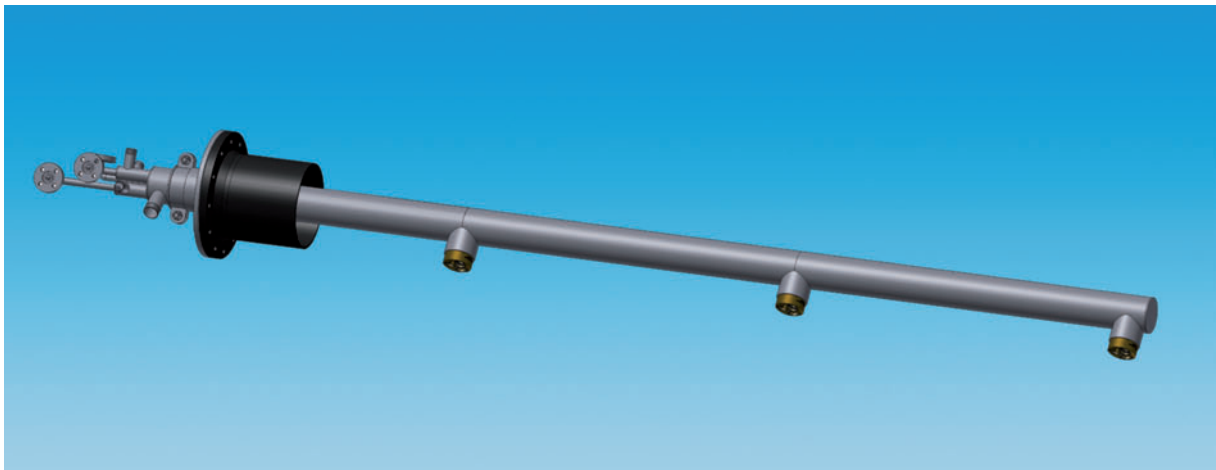

Nozzle lance for SCR applications (for installation in the gas duct)

COMPLETE SOLUTIONS

Pump and regulating units round off the program

Only when all components are optimally tailored to each other can a system make full use of its potential. That's why Lechler pump and regulating units are tailored very precisely to the process-specific requirements and the function of the nozzle lances. Preassembled, tested units with defined interfaces minimise the amount of installation and commissioning work for you.

Ammonia water or urea solutions can be used with Lechler pump and regulating units.

Many system variants, for example the distribution and exact dosing in various injection levels or taking into account special characteristics of the plant, are possible. Consult our experts.



Regulating unit



Pumping unit



Compact pump and regulating unit for installation in a container



Lechler GmbH
Precision Nozzles · Nozzle Systems
 P.O. Box 13 23
 72544 Metzingen / Germany
 Phone: +49 (0) 71 23 962-0
 Fax: +49 (0) 71 23 962-444

E-Mail: info@lechler.de
Internet: www.lechler.de



Over 130 years of practice and experience have resulted in know-how of an international standard. Interdisciplinary teams of process engineers, designers and production specialists are constantly working to enhance and optimise Lechler products at our main works in Metzingen near Stuttgart. Worldwide, 10 subsidiary companies and over 40 branches and representatives provide on-site support for our customers.



We are happy to provide you with support in commissioning and operator training, provided by our experienced staff.



China: Lechler Intl. Trad. Co. Ltd. · Beijing · Rm. 418 Landmark Tower · No. 8 Dong San Huan Bei Lu · Phone: (86) 1084537968, Fax: (86) 1084537458 · info@lechler.com.cn
Finland: Lechler Oy · Posliinitehtaankatu 7 · 04360 Kerava · Phone: (358) 207856880 · Fax: (358) 207856881 · info@lechler.fi
France/Belgium: Lechler France, S.A. · Bât. CAP2 B51 · 66-72, Rue Marceau · 93558 Montreuil cedex · Phone: (1) 49882600 · Fax: (1) 49882609 · info@lechler.fr
Great Britain: Lechler Ltd. · 1 Fell Street, Newhall · Sheffield, S9 2TP · Phone: (0114) 2492020 · Fax: (0114) 2493600 · info@lechler.com
India: Lechler (India) Pvt. Ltd. · Plot B-2 · Main Road · Wagle Industrial Estate · Thane (W) - 400604 · Phone: (22) 40634444 · Fax: (22) 40634497 · lechler@lechlerindia.com
Sweden: Lechler AB · Spärrgatan 8 · SE-653 41 Karlstad · Phone: (46) 54137030 · Fax: (46) 54137031 · info@lechler.se
Spain: Lechler S.A. · Avda. Pirineos 7 · Oficina B7, Edificio Inbisa I · 28700 San Sebastián de los Reyes, Madrid · Phone: (34) 916586346 · Fax: (34) 916586347 · info@lechler.es
USA: Lechler Inc. · 445 Kautz Road · St. Charles, IL. 60174 · Phone: (630) 3776611 · Fax: (630) 3776657 · info@lechlerUSA.com