

Lumiglas luminaire Lumistar

- For use on circular sight glass fittings**
 For combination of sight glass and light glass. Suitable for circular sight glass fittings to DIN 28120 and similar, DN 50 to DN 200.
- Application:**
 For illumination of internals of pressure vessels, tanks, bunkers, silos, stirred vessels and other normally enclosed containers in **non explosion hazardous areas**.
 Suitable for use in food processings.
- Protection:**
 When correctly fitted, dust and water jet tight to IP 65 and EN 60 529/DIN VDE 0470 part 1.
- Operating Conditions:**
 Independent of internal vessel pressure/vacuum;
 max. permissible ambient temperature measured at cable entry gland 80°C. Where ambient temp. > 40°C, heat resistant cable (e. g. type Sinotharm 110 H05GG-F 3G 1,5 mm²) must be fitted.
 The max. ambient temperature for Lumistar luminaires in LED-technology is: 40°C.
- Electrical data:**
 Power supply: 24 V
 Lamp: 2-pin Halogen filament lamp
 Power: depending on type 20 W, 50 W, 100 W Halogen filament lamp or 2 up to 22 W LED
 The luminaires Lumistar 150/175/225 with Halogen filament lamps are also available in 230 V-version.
- Lamp holder:** 2-pin socket
- Transformers:** Can be supplied as special accessory.
- Integral switch for brief 'ON' mode:**
 Not maintained push button switch fitted as standard.
- Mechanical installation:**
 - Before commencing installation please read information sheet 'Important guidelines for mounting sight glass fittings...'
 - Caution: Do not look into light – danger of impaired eyesight!
 - The luminaire is attached to the mating flange of the circular sight glass unit by two or four bolts. A ring gasket with bridge provides the seal between luminaire and sight glass disc.
 - The fixing bolts (stainless steel A2) are part of the supply.
 - Against additional cost, the Lumistar luminaire can be supplied complete with connecting cable.
- Electrical connection:**
 - Select connecting cable to suit operating conditions
 - Cable diameter to suit cable entry gland (M16x1.5)
 - Remove reflector
 - Bare cable core ends
 - Pass cable through gland into lamp chamber and connect to terminals (max. 2.5 mm²)
 - Tighten cable entry gland
 - Fit separately packed lamp using protective cloth
 - Replace reflector
- Lamp exchange:**
 - Caution: check luminaire temperature before commencing
 - Ensure power to luminaire switched off
 - Remove luminaire from mating flange
 - Remove reflector and pull out lamp

CE

also available
in LED-technology

3755.158 f



A complete unit, as supplied, of Lumiglas luminaire Lumistar

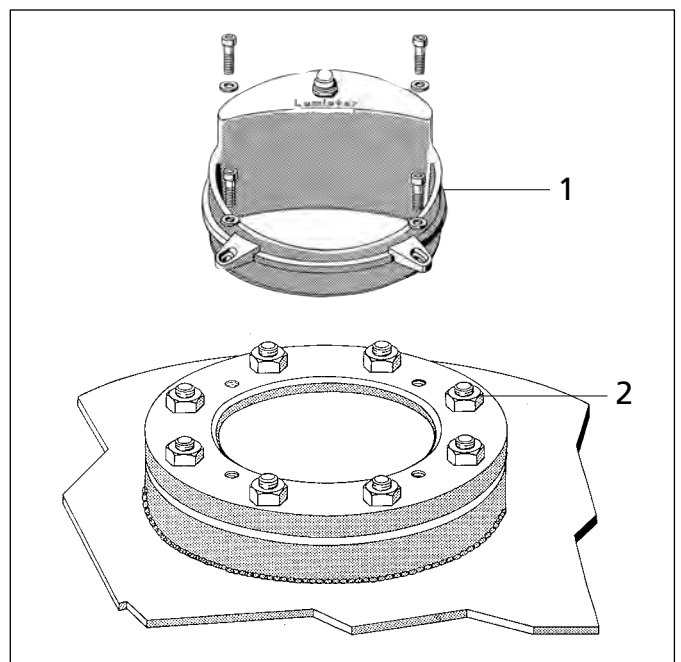

Sight- and light glasses are combined.

- (1) Lumiglas luminaire Lumistar, with fixing screws
- (2) Sight glass fitting DIN 28120 welded into vessel wall

- Fit new lamp by holding it with protective cloth and carefully locating into 2-pin socket and push home
- Replace reflector, checking for cleanliness
- Check condition of bridge gasket and replace if necessary
- Set luminaire on mating flange and bolt tight
- Switch on power

• Dimensions and connecting data for Lumiglas luminaire Lumistar

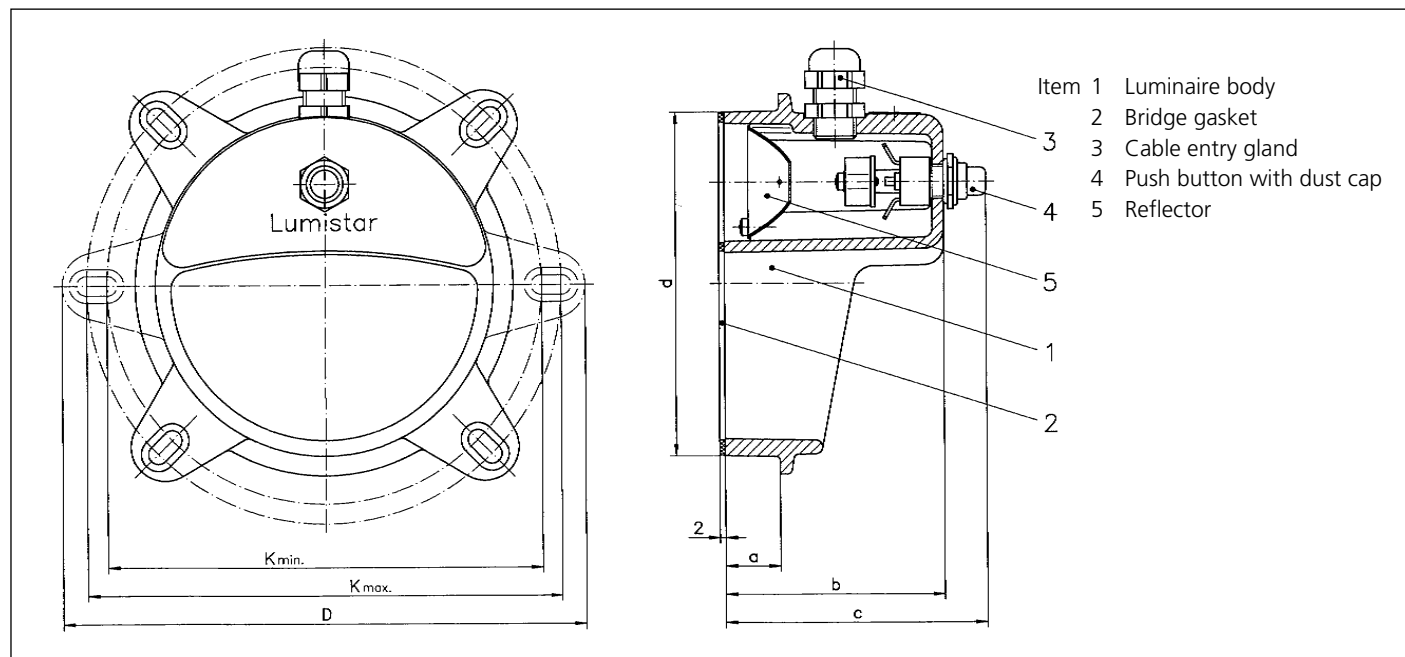

• Parts, construction and materials:

Luminaire body: Corrosion resistant die cast aluminium
Paint finish: RAL 9007

Size		1	2	3*	4*	5*	6*
Type Lumistar (= viewing diameter)		Lumistar 80	Lumistar 100 **	Lumistar 125 **	Lumistar 150 **	Lumistar 175 **	Lumistar 225 **
Matches to fitting DIN 28120	DN	50	80	100	125	150	200
Operating voltage	V	24	24	24	24	24	24
Power	W	20	50	50 or 100	50 or 100	50 or 100	50 or 100
Bolt pitch circle Ø	K min.	104	126	155	180	208	258
	K max.	118	140	169	194	222	282
	D	135	157	186	211	243	303
	d	77	97	122	147	172	222
	a	13	17	19	22	27	32
	b	65	75	77	80	85	95
	c	80	90	92	95	100	110
Fixing holes	oval hole	2 p.: 14 x 7	2 p.: 14 x 7	4 p.: 14 x 7	4 p.: 14 x 7	4 p.: 16 x 9	4 p.: 21 x 9
Bolts		M 6 x 16	M 6 x 16	M 6 x 16	M 6 x 16	M 8 x 16	M 8 x 16
Weight appx.	kg	0.300	0.450	0.550	0.650	0.800	1.400
Part no.		3544.001.00	3544.007.00	3544.014.00	3544.019.00	3544.024.00	3544.029.00

* Can be combined with Lumiglas sight glass wiper SW1

** also available in LED-technology

• Order data: e. g. Lumiglas luminaire Lumistar 125, Part no. 3544.019.00, 24 V/100 W

The appropriate lamp, corresponding to the required power, is separately packed as part of the supply.

Hence the importance of stating desired lamp power; in absence of such information, a lamp considered correct for the specified luminaire model will be sent.