

Models HSR-R, HSR-RM, HSR-LR and HSR-LRM

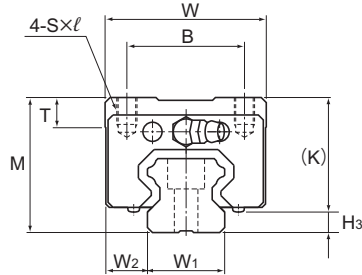

Model No.	Outer dimensions			LM block dimensions									Grease nipple	H ₃
	Height	Width	Length	B	C	S×ℓ	L ₁	T	K	N	E			
	M	W	L											
HSR 15R HSR 15RM	28	34	56.6	26	26	M4×5	38.8	6	23.3	8.3	5.5	PB1021B	4.7	
HSR 20R HSR 20RM	30	44	74	32	36	M5×6	50.8	8	26	5	12	B-M6F	4	
HSR 20LR HSR 20LRM	30	44	90	32	50	M5×6	66.8	8	26	5	12	B-M6F	4	
HSR 25R HSR 25RM	40	48	83.1	35	35	M6×8	59.5	9	34.5	10	12	B-M6F	5.5	
HSR 25LR HSR 25LRM	40	48	102.2	35	50	M6×8	78.6	9	34.5	10	12	B-M6F	5.5	
HSR 30R HSR 30RM	45	60	98	40	40	M8×10	70.4	9	38	10	12	B-M6F	7	
HSR 30LR HSR 30LRM	45	60	120.6	40	60	M8×10	93	9	38	10	12	B-M6F	7	
HSR 35R HSR 35RM	55	70	109.4	50	50	M8×12	80.4	11.7	47.5	15	12	B-M6F	7.5	
HSR 35LR HSR 35LRM	55	70	134.8	50	72	M8×12	105.8	11.7	47.5	15	12	B-M6F	7.5	
HSR 45R HSR 45LR	70	86	139 170.8	60	60 80	M10×17	98 129.8	15	60	20	16	B-PT1/8	10	
HSR 55R HSR 55LR	80	100	163 201.1	75	75 95	M12×18	118 156.1	20.5	67	21	16	B-PT1/8	13	
HSR 65R HSR 65LR	90	126	186 245.5	76	70 120	M16×20	147 206.5	23	76	19	16	B-PT1/8	14	
HSR 85R HSR 85LR	110	156	245.6 303	100	80 140	M18×25	178.6 236	29	94	23	16	B-PT1/8	16	

Model number coding

HSR35 R 2 QZ SS C0 M +1400L P T M - II

Model number

Type of LM block

With QZ Lubricator

Contamination protection accessory symbol (*1)

Stainless steel LM block

LM rail length (in mm)

Stainless steel LM rail

Symbol for LM rail jointed use

Symbol for No. of rails used on the same plane (*4)

No. of LM blocks used on the same rail

Radial clearance symbol (*2)
Normal (No symbol)
Light preload (C1)
Medium preload (C0)

Accuracy symbol (*3)
Normal grade (No Symbol)/High accuracy grade (H)
Precision grade (P)/Super precision grade (SP)
Ultra precision grade (UP)

(*1) See contamination protection accessory on **A1-510**. (*2) See **A1-71**. (*3) See **A1-77**. (*4) See **A1-13**.

Note) This model number indicates that a single-rail unit constitutes one set. (i.e., required number of sets when 2 rails are used in parallel is 2 at a minimum.)

Those models equipped with QZ Lubricator cannot have a grease nipple.

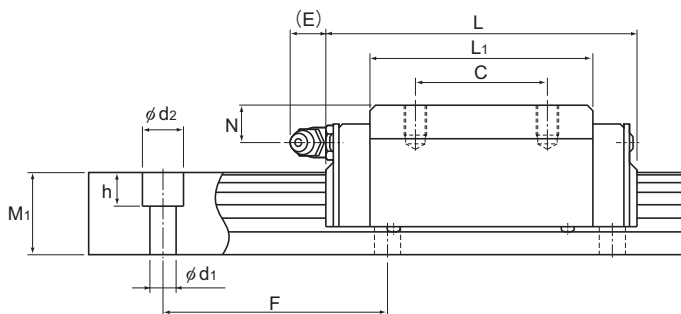

Unit: mm

	LM rail dimensions						Basic load rating		Static permissible moment kN-m*					Mass	
	Width		Height	Pitch		Length*	C	C ₀	M _a		M _b		M _c	LM block	LM rail
	W ₁ ±0.05	W ₂	M ₁	F	d ₁ × d ₂ × h	Max	kN	kN	1 block	Double blocks	1 block	Double blocks	1 block	kg	kg/m
	15	9.5	15	60	4.5 × 7.5 × 5.3	3000 (1240)	8.33	13.5	0.0805	0.457	0.0805	0.457	0.0844	0.18	1.5
	20	12	18	60	6 × 9.5 × 8.5	3000 (1480)	13.8	23.8	0.19	1.04	0.19	1.04	0.201	0.25	2.3
	20	12	18	60	6 × 9.5 × 8.5	3000 (1480)	21.3	31.8	0.323	1.66	0.323	1.66	0.27	0.35	2.3
	23	12.5	22	60	7 × 11 × 9	3000 (2020)	19.9	34.4	0.307	1.71	0.307	1.71	0.344	0.54	3.3
	23	12.5	22	60	7 × 11 × 9	3000 (2020)	27.2	45.9	0.529	2.74	0.529	2.74	0.459	0.67	3.3
	28	16	26	80	9 × 14 × 12	3000 (2520)	28	46.8	0.524	2.7	0.524	2.7	0.562	0.9	4.8
	28	16	26	80	9 × 14 × 12	3000 (2520)	37.3	62.5	0.889	4.37	0.889	4.37	0.751	1.1	4.8
	34	18	29	80	9 × 14 × 12	3000 (2520)	37.3	61.1	0.782	3.93	0.782	3.93	0.905	1.5	6.6
	34	18	29	80	9 × 14 × 12	3000 (2520)	50.2	81.5	1.32	6.35	1.32	6.35	1.2	2	6.6
	45	20.5	38	105	14 × 20 × 17	3090	60 80.4	95.6 127	1.42 2.44	7.92 12.6	1.42 2.44	7.92 12.6	1.83 2.43	2.6 3.1	11
	53	23.5	44	120	16 × 23 × 20	3060	88.5 119	137 183	2.45 4.22	13.2 21.3	2.45 4.22	13.2 21.3	3.2 4.28	4.3 5.4	15.1
	63	31.5	53	150	18 × 26 × 22	3000	141 192	215 286	4.8 8.72	23.5 40.5	4.8 8.72	23.5 40.5	5.82 7.7	7.3 9.3	22.5
	85	35.5	65	180	24 × 35 × 28	3000	210 282	310 412	8.31 14.2	45.6 72.5	8.31 14.2	45.6 72.5	11 14.7	13 16	35.2

Note) Symbol M indicates that stainless steel is used in the LM block, LM rail and balls. Those models marked with this symbol are therefore highly resistant to corrosion and environment.

The maximum length under "Length*" indicates the standard maximum length of an LM rail. (See **A1-204**.)

Static permissible moment*: 1 block: static permissible moment value with 1 LM block

Double blocks: static permissible moment value with 2 blocks closely contacting with each other