

Model SKR46 Standard Type

Model SKR46□□C (with a Single Short Nut Block)

Model SKR46□□D (with Two Short Nut Blocks)

For model number coding, see **A2-24**.

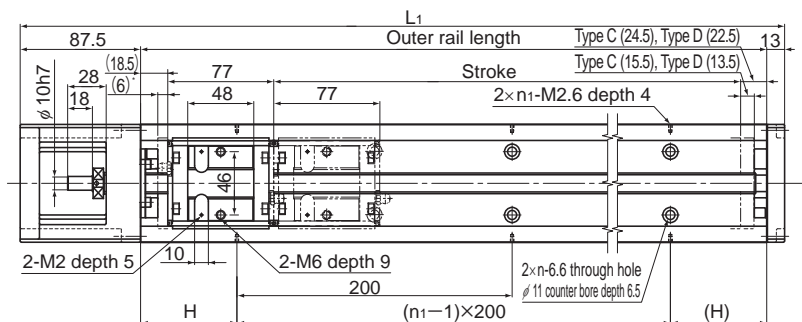

* Distance between the mechanical stopper and the stroke starting position.

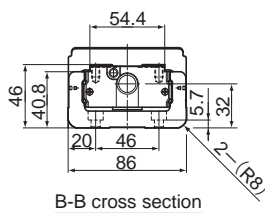
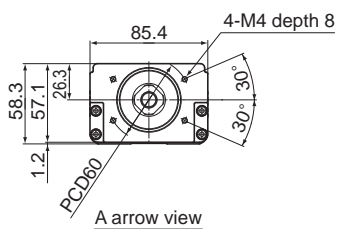
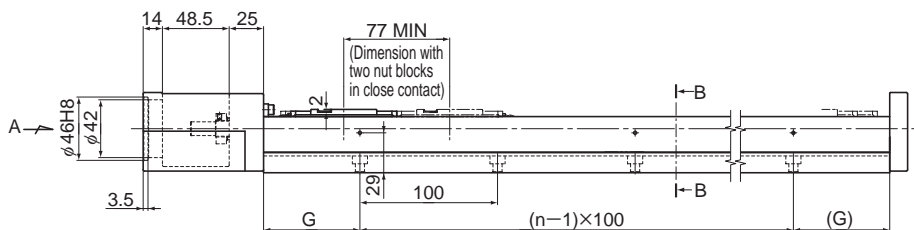

Stroke (mm) (stroke between mechanical stoppers)		Outer rail length (mm)	Overall length L_1 (mm)	H (mm)	G (mm)	n	n_1	Overall main unit mass (kg)	
Type C	Type D							Type C	Type D
220(241.5)	145(164.5)	340	440.5	70	70	3	2	6.1	6.7
320(341.5)	245(264.5)	440	540.5	20	70	4	3	7.5	8.1
420(441.5)	345(364.5)	540	640.5	70	70	5	3	8.9	9.5
520(541.5)	445(464.5)	640	740.5	20	70	6	4	10.3	10.8
620(641.5)	545(564.5)	740	840.5	70	70	7	4	11.7	12.2
720(741.5)	645(664.5)	840	940.5	20	70	8	5	13.1	13.7
820(841.5)	745(764.5)	940	1040.5	70	70	9	5	14.5	15.0

*Indicates a value when two inner blocks are in close contact with each other.

Model SKR46 (with a Cover)

Model SKR46□□C (with a Single Short Nut Block)

Model SKR46□□D (with Two Short Nut Blocks)

For model number coding, see **A2-24**.

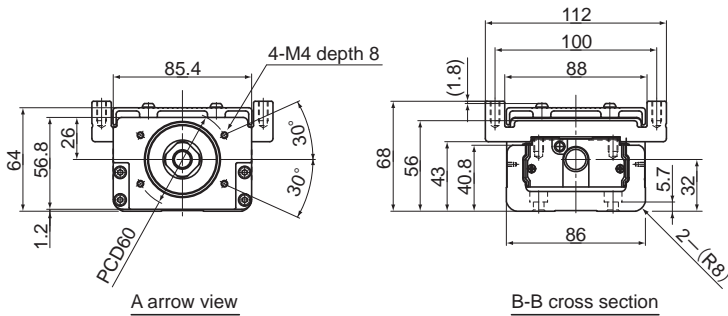
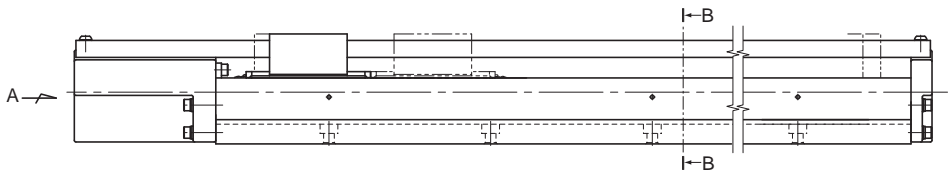
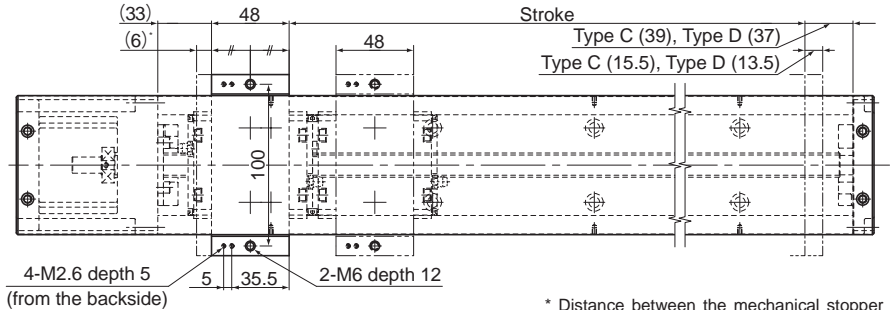

Stroke (mm) (stroke between mechanical stoppers)		Outer rail length (mm)	Overall length L:(mm)	H (mm)	G (mm)	n	n ₁	Overall main unit mass (kg)	
Type C	Type D*							Type C	Type D
220(241.5)	145(164.5)	340	440.5	70	70	3	2	6.6	7.4
320(341.5)	245(264.5)	440	540.5	20	70	4	3	8.1	8.9
420(441.5)	345(364.5)	540	640.5	70	70	5	3	9.6	10.3
520(541.5)	445(464.5)	640	740.5	20	70	6	4	11.0	11.8
620(641.5)	545(564.5)	740	840.5	70	70	7	4	12.5	13.3
720(741.5)	645(664.5)	840	940.5	20	70	8	5	14	14.8
820(841.5)	745(764.5)	940	1040.5	70	70	9	5	15.5	16.3

*Indicates a value when two inner blocks are in close contact with each other.