

Model LMK-ML (Stainless Steel Type)

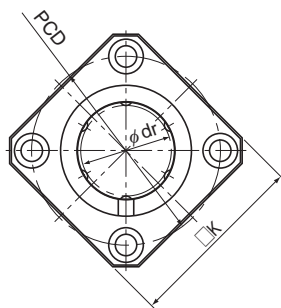

Model LMK-ML

Model No. Standard type	Ball rows	Main dimensions							
		Inscribed bore diameter		Outer diameter		Length		Flange diameter	
		dr	Tolerance	D	Tolerance	L	Tolerance	D ₁	Tolerance
LMK 6ML	4	6	0 -0.010	12	0	35	0 -0.3	28	0 -0.2
LMK 8ML	4	8		15	-0.013	45		32	
LMK 10ML	4	10		19	0 -0.016	55		39	
LMK 12ML	4	12		21		57		42	
LMK 13ML	4	13		23		61		43	
LMK 16ML	5	16	28	70	48				
LMK 20ML	5	20	32	0	80	54			
LMK 25ML	6	25	40	0 -0.019	112	0	62		
LMK 30ML	6	30	45		123	-0.4	74		

Note) Since this model contains a synthetic resin retainer, do not use it at temperature exceeding 80°C.
If requiring a type equipped with a seal, indicate it when placing an order.

(Example) LMK8ML UU

└── Seal attached on both ends of the nut

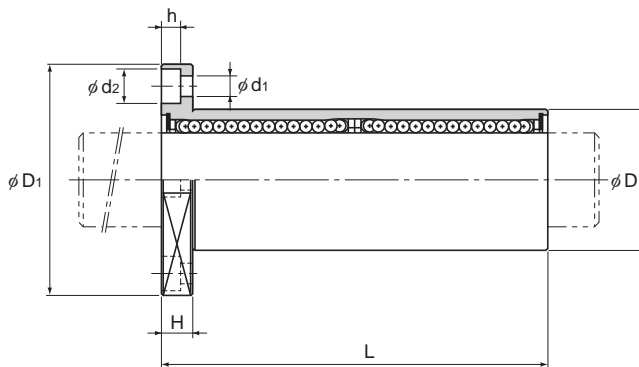

Unit: mm

	K	H	PCD	Mounting hole $d_1 \times d_2 \times h$	Flange perpendicularity	Eccentricity (max)	Radial clearance tolerance	Basic load rating		Mass g
					μm	μm	μm	C N	C_0 N	
	22	5	20	$3.4 \times 6.5 \times 3.3$	15	15	-5	324	529	26
	25	5	24	$3.4 \times 6.5 \times 3.3$	15	15	-5	431	784	46
	30	6	29	$4.5 \times 8 \times 4.4$	15	15	-5	588	1100	88
	32	6	32	$4.5 \times 8 \times 4.4$	15	15	-5	657	1200	82
	34	6	33	$4.5 \times 8 \times 4.4$	15	15	-7	814	1570	108
	37	6	38	$4.5 \times 8 \times 4.4$	15	15	-7	1230	2350	160
	42	8	43	$5.5 \times 9.2 \times 5.4$	20	20	-9	1400	2750	230
	50	8	51	$5.5 \times 9.2 \times 5.4$	20	20	-9	1560	3140	475
	58	10	60	$6.6 \times 11 \times 6.5$	20	20	-9	2490	5490	575

Note) Since the nut and the balls use stainless steel, these models are highly resistant to corrosion and environment.