

R Guide Model HCR

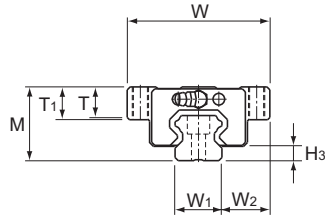

Model No.	Outer dimensions			LM block dimensions									H ₃
	Height	Width	Length	B	C	S	L ₁	T	T ₁	N	E	Grease nipple	
	M	W	L										
HCR 12A+60/100R	18	39	44.6	32	18	M4	30.5	4.5	5	3.4	3.5	PB107	3.1
HCR 15A+60/150R	24	47	54.5	38	24	M5	38.8	10.3	11	4.5	5.5	PB1021B	4.8
HCR 15A+60/300R			55.5										
HCR 15A+60/400R	36	70	81.6	57	45	M8	59.5	14.9	16	6	12	B-M6F	7
HCR 25A+60/500R			82.3										
HCR 25A+60/1000R			82.5										
HCR 35A+60/600R	48	100	107.2	82	58	M10	80.4	19.9	21	8	12	B-M6F	8.5
HCR 35A+60/800R			107.5										
HCR 35A+60/1000R			108.2										
HCR 35A+60/1300R			108.5										
HCR 45A+60/800R	60	120	136.7	100	70	M12	98	23.9	25	10	16	B-PT1/8	11.5
HCR 45A+60/1000R			137.3										
HCR 45A+60/1200R			137.3										
HCR 45A+60/1600R			138										
HCR 65A+60/1000R			193.8										
HCR 65A+60/1500R	195.4	90	170	142	106	M16	147	34.9	37	19	16	B-PT1/8	15
HCR 65A+45/2000R	195.9												
HCR 65A+45/2500R	196.5												
HCR 65A+30/3000R	196.5												

Model number coding

HCR25A 2 UU C1 +60 / 1000R H 6 T

Model number

Contamination protection accessory symbol (*1)

R-Guide center angle

LM rail radius (in mm)

Symbol for LM rail jointed use

No. of LM blocks used on the same rail

Radial clearance symbol (*2)
Normal (No symbol)
Light preload (C1)

Accuracy symbol (*3)
Normal grade (No Symbol)
High accuracy grade (H)

Number of LM rail joints used on one axis (*4)

(*1) See **A1-510** (contamination protection accessories). (*2) See **A1-72**. (*3) See **A1-79**.

(*4) Number of LM rails used on one arc. For details, contact THK.

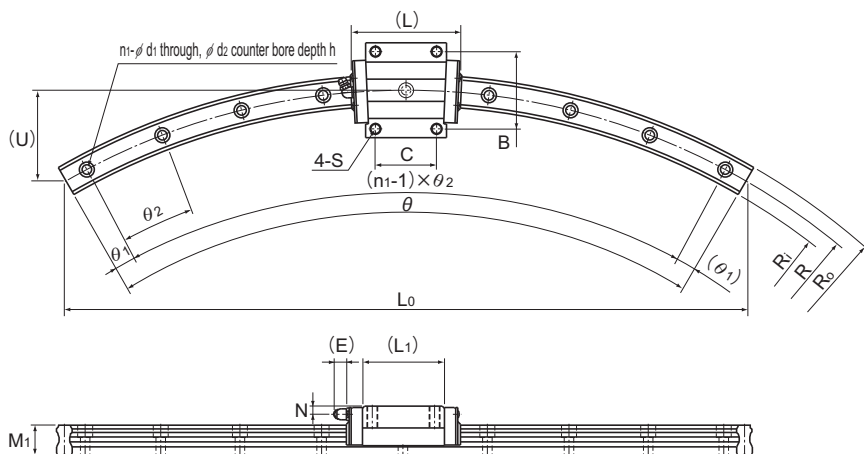

Unit: mm

LM rail dimensions														Basic load rating		Static permissible moment kN-m*					Mass	
R	R ₀	R _i	L ₀	U	W ₁	W ₂	M ₁	d ₁ × d ₂ × h	n ₁	θ°	θ ₁ °	θ ₂ °	C	C ₀	M _A		M _B		M _C	LM block	LM rail	
													kN	kN	1 block	Double blocks	1 block	Double blocks	1 block	kg	kg/m	
100	106	94	100	13.4	12	13.5	11	3.5×6×5	3	60	7	23	4.7	8.53	0.0409	0.228	0.0409	0.228	0.0445	0.08	0.83	
150	157.5	142.5	150	20.1					3	7	23	6.66	10.8									
300	307.5	292.5	300	40	15	16	15	4.5×7.5×5.3	5	60	6	12	8.33	13.5	0.0805	0.457	0.0805	0.457	0.0844	0.2	1.5	
400	407.5	392.5	400	54					7	3	9	8.33	13.5									
500	511.5	488.5	500	67					9	2	7											
750	761.5	738.5	750	100	23	23.5	22	7×11×9	12	60	2.5	5	19.9	34.4	0.307	1.71	0.307	1.71	0.344	0.59	3.3	
1000	1011.5	988.5	1000	134					15	2	4											
600	617	583	600	80					7	3	9											
800	817	783	800	107	34	33	29	9×14×12	11	60	2.5	5.5	37.3	61.1	0.782	3.93	0.782	3.93	0.905	1.6	6.6	
1000	1017	983	1000	134					12	2.5	5											
1300	1317	1283	1300	174					17	2	3.5											
800	822.5	777.5	800	107					8	2	8											
1000	1022.5	977.5	1000	134	45	37.5	38	14×20×17	10	60	3	6	60	95.6	1.42	7.92	1.42	7.92	1.83	2.8	11.0	
1200	1222.5	1177.5	1200	161					12	2.5	5											
1600	1622.5	1577.5	1600	214					15	2	4											
1000	1031.5	968.5	1000	134					8	60	2	8										
1500	1531.5	1468.5	1500	201					10	60	3	6										
2000	2031.5	1968.5	1531	152	63	53.5	53	18×26×22	12	45	0.5	4	141	215	4.8	23.5	4.8	23.5	5.82	8.5	22.5	
2500	2531.5	2468.5	1913	190					13	45	1.5	3.5										
3000	3031.5	2968.5	1553	102					10	30	1.5	3										

Note) LM rail radiuses other than the radiuses in the above table are also available. Contact THK for details.

The R-Guide center angles in the table are maximum manufacturing angles. To obtain angles greater than them, rails must be additionally connected. Contact THK for details.

Static permissible moment*: 1 block: static permissible moment value with 1 LM block

Double blocks: static permissible moment value with 2 blocks closely contacting with each other