

Price index



Low noise version E4/101  
Series 281 available with  
special rubber pads design



IPA Certificate, Cleanroom ISO  
Class 3 at v=1 m/s and ISO Class  
4 at v= 2 m/s for Series 280.10.100.0



ESD classification:  
Electrically conductive ESD/ATEX  
version upon request



Opening e-chains®: Remove crossbars and  
clips - Insert screwdriver into the slot, push  
down, release by lever action



Remove lids/bottoms (e-tubes) - Insert screw-  
driver into the slot, release by lever action



When to use the Series 280/290/R770:

- If a low-noise version is required
- At very high speeds and/or accelerations
- For long travels
- For high additional loads
- Also available without camber



When not to use it:

- If long side-mounted, unsupported length is required  
▶ Series E4.32, page 7.42
- If an extrem vibration-free e-chain® is necessary  
▶ Series E6.35, page 8.50

- ① Crossbars on e-chain® removable  
along both radii
- ② Numerous interior separation possibilities
- ③ Closed and open styles can be combined
- ④ Stop dog with "brake" for noise reduction
- ⑤ Optimized glide pads
- ⑥ Wide, rounded plastic crossbars - cable friendly
- ⑦ Hinged snap-open removable lids  
along outer radius of e-tube
- ⑧ KMA mounting brackets with  
attachment points on all sides
- ⑨ Locking or pivoting mounting brackets available
- ⑩ Integrated strain relief with C-profile option
- ⑪ e-chains® also available with  
reverse bending radius "RBR"



Also available as  
E4/00-NC without  
camber: 280-NC

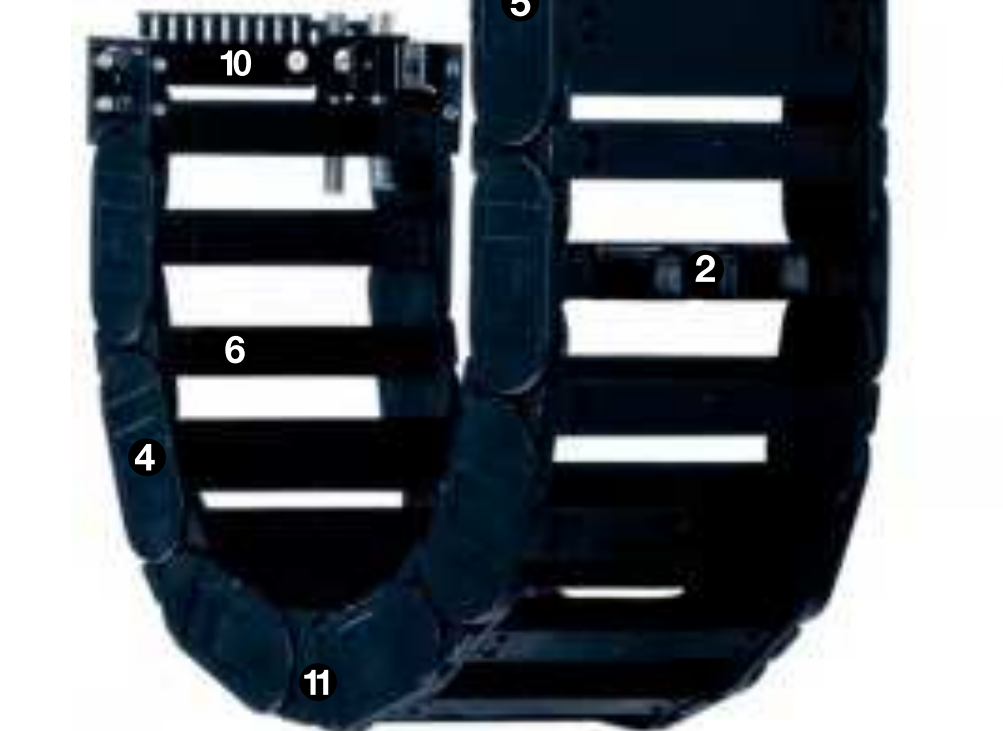

Order example complete e-chain®

Please indicate chain-lengths or number of links Example: 4 m or 72 links

4 m 280.30.300.0

e-chain®

with 2 separators 282 assembled every 2<sup>nd</sup> link

Interior separation

1 set 2800.30.1.12.C

Mounting bracket



**Unsupported length**

$FL_G$  = with straight upper run  
 $FL_B$  = with permitted sag  
 Further information ► **Design, page 1.12**

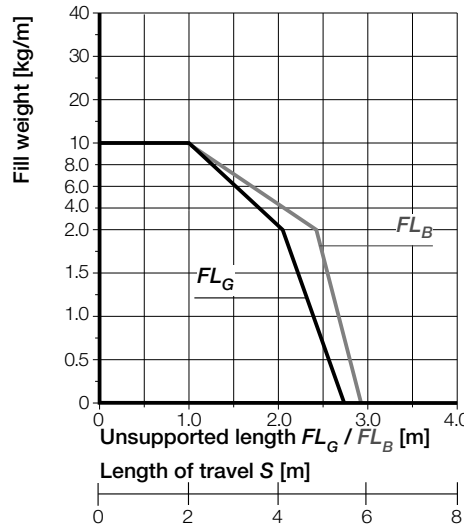
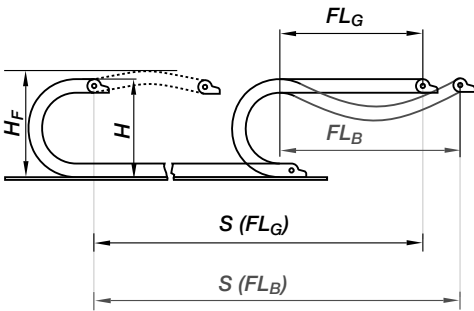

- $S$  = Length of travel
  - $R$  = Bending radius
  - $H$  = Nominal clearance height
  - $H_F$  = Required clearance height
  - $H_{RI}$  = Trough inner height
  - $D$  = Overlength e-chain\* radius in final position
  - $K = \pi \cdot R + \text{"safety"}$
  - $D_2$  = Over length - long travels, gliding
  - $K_2$  = \*Further add-on
  - $H_2$  = \*Mounting height
- \*if the mounting bracket location is set lower

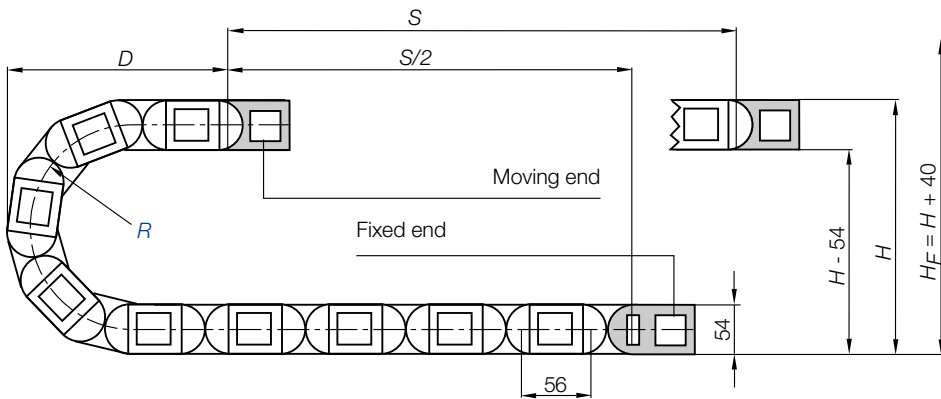

**Pitch = 56 mm/link    Links/m = 18 (1008 mm)    Chain length =  $S/2 + K$**

R	063	075	100	125	150	175	200	220	250	300
$H_{+20}$	180	205	255	305	355	405	455	495	555	655
D	146	158	183	208	233	258	283	303	333	383
K	310	350	430	505	585	665	745	805	900	1055
$H_2$	126	151	166	166	166	166	166	166	166	166
$D_2^{+25}$	146	158	370	470	500	655	770	900	930	1100
$K_2$	310	350	616	784	896	1120	1288	1456	1568	1904

**Other installation methods**

- Vertical, hanging  $\leq 80$  m
- Vertical, standing  $\leq 5$  m
- Side mounted, unupp.  $\leq 1,5$  m
- Rotary requires further calculation
- Unsupported length of upper run = upon request

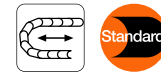

**Short travels - unsupported**

Unsupported e-chains\* feature positive camber over short travels. This must be accounted for when specifying the clearance height  $H_F$ . Please consult igus\* if space is particularly restricted.

The required clearance height:  
 $H_F = H + 40$  mm  
 (with 2,0 kg/m fill weight)

**Long travel lengths from 10 m to max. 200 m    Chain length =  $S/2 + K_2$**

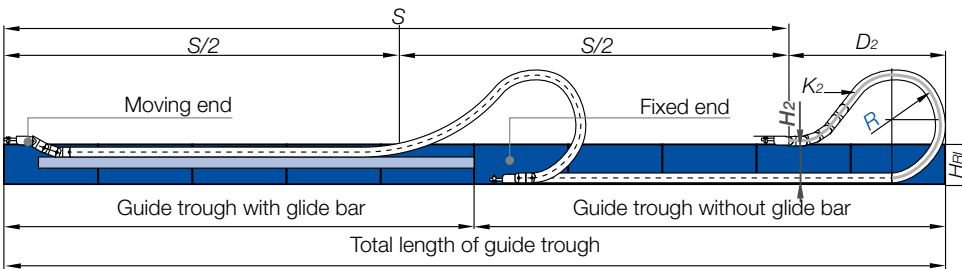

In case of travels between 6,0 and 10 m we recommend a longer unsupported length.



**Gliding, long travel applications (max. 200 m)**

In this case the e-chain\* upper run will be introduced in a guide trough on the lower run. We recommend to realize the engineering of such a plant by our technicians.

**Technical Data**

Speed / acceleration $FL_G$	max. 20 [m/s] / max. 200 [m/s <sup>2</sup> ]
Speed / acceleration $FL_B$	max. 3 [m/s] / max. 6 [m/s <sup>2</sup> ]
Gliding speed / acceleration (maximum)	max. 10 [m/s] / max. 50 [m/s <sup>2</sup> ]
Material - permitted temperature °C	igumid G / -40° up to +120° C
Flammability class, igumid G	VDE 0304 IIC UL94 HB



Details of material properties  
 ► **page 1.38**

For support of the lower run - **Support Tray tool kit available ► page 9.70**



**System E4/00**  
**Inner height: 32 mm**

**Phone +49- (0) 22 03-96 49-800**  
**Fax +49- (0) 22 03-96 49-222**

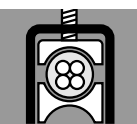

► **page 7.255**

igus® e-chainsystems®

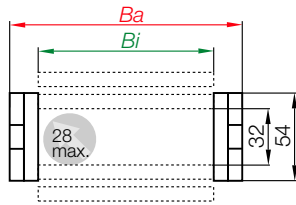

Part No. structure

280.	30.	300.	0
------	-----	------	---



Series 280 - e-chain® with crossbars every link

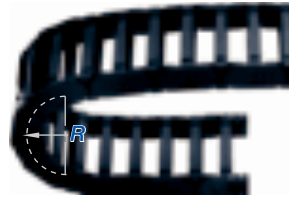

- Crossbars every link
- For rigid hydraulic hoses
- For applications particularly demanding
- Can be opened from two sides



Phone +49- (0) 22 03-96 49-800  
Fax +49- (0) 22 03-96 49-222



Series 290 - e-chain® with crossbars every 2<sup>nd</sup> link

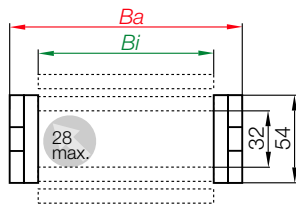

Part No. structure

290.	20.	300.	0
------	-----	------	---

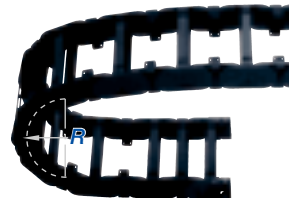

- Crossbars every 2<sup>nd</sup> link = Standard
- For nearly every situation
- Can be opened from two sides
- Easy assembly
- Stable
- Attractive price



igus® GmbH  
51147 Cologne

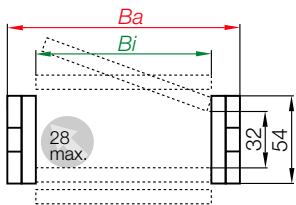

Part No. structure

770.	30.	300.	0
------	-----	------	---



Series R770 - Fully enclosed e-tube

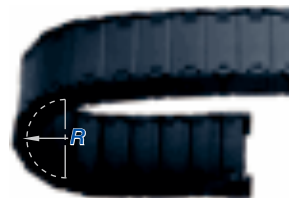

- Fully enclosed
- Excellent cable protection against dirt
- Protection against hot chips (up to 900°C)
- Lids along the entire inner radius are completely removable. Lids along the entire outer radius are single sided snap-open with a hinge on the other side to keep them attached to the chain or completely removable.



Internet: [www.igus.eu](http://www.igus.eu)  
E-mail: [info@igus.de](mailto:info@igus.de)

Low-noise! Special low-noise version with rubber pads

Series 281 - Order example 281.10.250.0

Further information:

[www.igus.de](http://www.igus.de) or phone +49-(0) 22 03-96 49-800

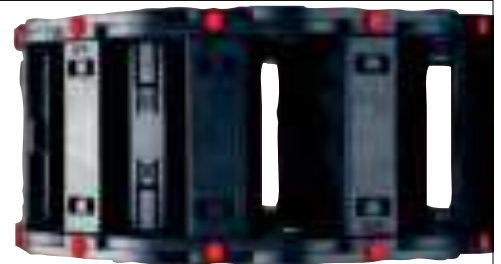

Part No.		<i>Bi</i> [mm]	<i>Ba</i> [mm]	280 [kg/m]	290 [kg/m]	R770 [kg/m]
280/290/770.05...	<input type="checkbox"/> .0*	50	73	≈ 1,73	≈ 1,64	≈ 2,63
280/290.06.....	<input type="checkbox"/> .0	68	91	≈ 1,79	≈ 1,67	-
280/290/770.07...	<input type="checkbox"/> .0	75	98	≈ 1,84	≈ 1,69	≈ 2,75
280/290.087.....	<input type="checkbox"/> .0	87	110	≈ 1,93	≈ 1,73	-
280/290/770.10...	<input type="checkbox"/> .0	100	123	≈ 2,02	≈ 1,78	≈ 2,83
280/290/770.11...	<input type="checkbox"/> .0	108	131	≈ 2,08	≈ 1,81	≈ 2,94
280/290.112.....	<input type="checkbox"/> .0	112	136	≈ 2,15	≈ 1,84	-
280/290/770.12...	<input type="checkbox"/> .0	125	148	≈ 2,20	≈ 1,87	≈ 3,03
280/290.137.....	<input type="checkbox"/> .0	137	161	≈ 2,29	≈ 1,91	-
280/290/770.15...	<input type="checkbox"/> .0	150	173	≈ 2,38	≈ 1,96	≈ 3,19
280/290.162.....	<input type="checkbox"/> .0	162	186	≈ 2,44	≈ 1,99	-
280/290/770.17...	<input type="checkbox"/> .0	168	191	≈ 2,51	≈ 2,02	≈ 3,39
280/290.18.....	<input type="checkbox"/> .0	175	198	≈ 2,56	≈ 2,05	-
280/290.187.....	<input type="checkbox"/> .0	187	211	≈ 2,65	≈ 2,09	-
280/290/770.20...	<input type="checkbox"/> .0	200	223	≈ 2,74	≈ 2,14	≈ 3,59
280/290.212.....	<input type="checkbox"/> .0	212	236	≈ 2,87	≈ 2,20	-
280/290.23.....	<input type="checkbox"/> .0	225	248	≈ 2,92	≈ 2,22	-
280/290.237.....	<input type="checkbox"/> .0	237	261	≈ 3,05	≈ 2,29	-
280/290/770.25...	<input type="checkbox"/> .0	250	273	≈ 3,10	≈ 2,32	≈ 4,04
280/290.262.....	<input type="checkbox"/> .0	262	286	≈ 3,19	≈ 2,36	-
280/290.28.....	<input type="checkbox"/> .0	275	298	≈ 3,28	≈ 2,41	-
280/290.29.....	<input type="checkbox"/> .0	287	311	≈ 3,37	≈ 2,45	-
280/290/770.30...	<input type="checkbox"/> .0	300	323	≈ 3,46	≈ 2,50	≈ 4,43
280/290.312.....	<input type="checkbox"/> .0	312	336	≈ 3,59	≈ 2,56	-
280/290.325.....	<input type="checkbox"/> .0	325	348	≈ 3,68	≈ 2,60	-
280/290.337.....	<input type="checkbox"/> .0	337	361	≈ 3,77	≈ 2,65	-
280/290.350.....	<input type="checkbox"/> .0	350	373	≈ 3,86	≈ 2,69	-
280/290.362.....	<input type="checkbox"/> .0	362	386	≈ 3,95	≈ 2,74	-
280/290.375.....	<input type="checkbox"/> .0	375	398	≈ 4,04	≈ 2,79	-
280/290.387.....	<input type="checkbox"/> .0	387	411	≈ 4,11	≈ 2,82	-
280/290.400.....	<input type="checkbox"/> .0	400	423	≈ 4,18	≈ 2,86	-

Available bending radii

R [mm] 063\*\* 075\*\* 100\*\* 125 150 175 200 220 250 300

Supplement Part No. with required radius. Example: 280.30.300.0

0 = standard color, other colors ▶ page 1.39 · Pitch = 56 mm/link - Links/m = 18

\*Removable lid only, no hinged option · \*\*not available for R770

## Hot Chips up to 850°C

e-tubes that repel hot chips, up to 850°C. Some applications, depending on amount and size of the chips, can burn or melt the surface. That is no longer the case with the igus® "igumid HT" material. Order example: Full e-tube made of HT\*: **770.30.150.0.HT**  
Lids made of HT: **770.30.HTE.150.0**  
\*for long travels upon request  
Further Information: [www.igus.de/en/HT](http://www.igus.de/en/HT)  
Delivery time up to 4 weeks!



System E4/00  
Inner height: 32 mm

Phone +49- (0) 22 03-96 49-800  
Fax +49- (0) 22 03-96 49-222



Extender crossbar for large diameter hoses ▶ page 7.270



▶ page 7.255

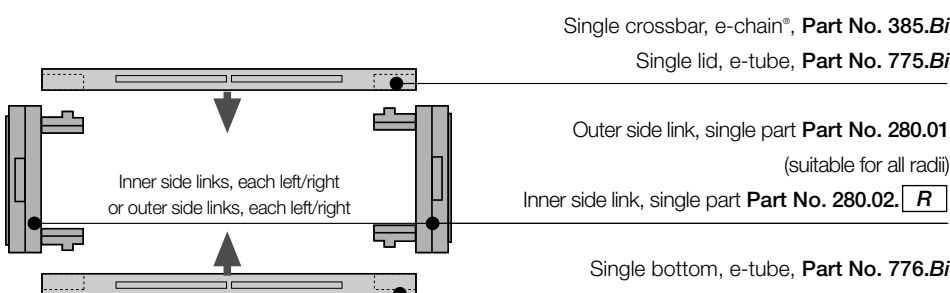

### Part No. e-chain® links, single parts

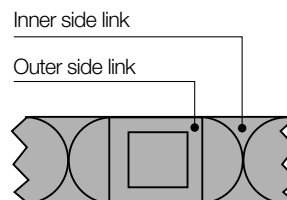

igus® e-chainsystems®



Vertical separators are used if a vertical subdivision is required. In the standard configuration, a separator is mounted at every second link. **Note:** Observe a lateral spacing of at least 25 mm (e-tube)!

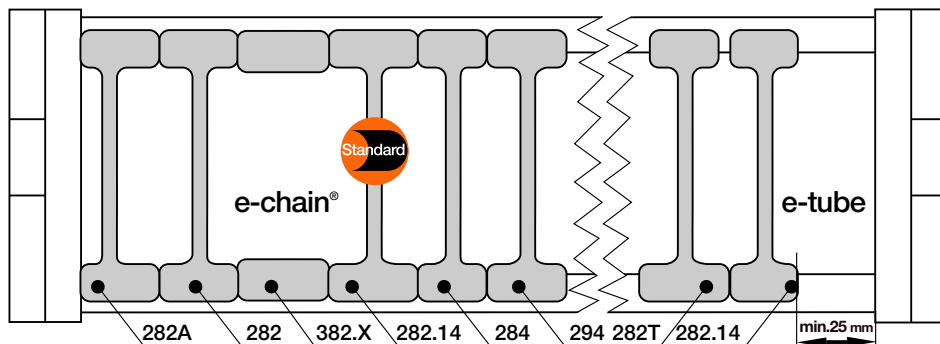

Phone +49- (0) 22 03-96 49-800  
Fax +49- (0) 22 03-96 49-222

igus® GmbH  
51147 Cologne

Internet: www.igus.eu  
E-mail: info@igus.de



Vertical separator 281



Vertical separator 281T



Vertical separator 281.14



Vertical separator 283



Spacer 381.XX



Locking separator 293



Asymmetric separator 281A

**Vertical separator for e-chains®**

unassembled	281
assembled	282

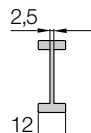

**Vertical separator for e-tubes**

unassembled	281T
assembled	282T

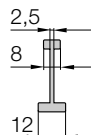

**Vertical separator for e-chains®/e-tubes**

unassembled	281.14
assembled	282.14

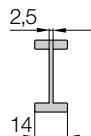

**Vertical separator for e-chains®**

unassembled	283
assembled	284

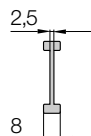

**Spacer\* for e-chains®**

unassembled	381.XX
assembled	382.XX

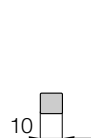

**Locking separator for e-chains®**

unassembled	293
assembled	294

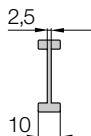

**Asymmetric separator for e-chains®**

unassembled	281A
assembled	282A

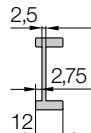

\*For side-mounted applications

**Option 1: Vertical separators and spacers**

● **Standard separator 281 for e-chains®** offers safe stability due to its broad foot design, also when used with thick cables or hoses. If the distance needed between separators is greater than this separator's dimension, we offer the **Vertical separator 281.14**.

● The **vertical separator 281T for e-tubes** clamps to the fixed radius and remains free along the other radius to facilitate lid removal. If installing these yourself, please ensure that they are identically aligned. If the distance needed between separators is greater than this separator's dimension, we offer the **Vertical separator 281.14**.

● **Vertical separator 283 with a narrow foot for e-chains®** with applications where a large number of small cables need to be individually separated.

● Separators (e.g. "side mounted") for e-chains® can be fixed in their position with **spacers 381.XX**. The available inner height will be reduced by 2 mm, per spacer and side. To avoid this, the parts can be assembled on outside of the crossbar (not for long travels) **XX = width of the spacer** (available 10, 15 and 20).

**Additionally:**

● **Locking separator 293 for e-chains®** - with increased retention force for applications exposed to very high humidity or extreme loads. The extra retention force is achieved by asymmetric claws for the crossbar. Ensure proper alignment (not for e-tubes).

● **Asymmetric separator 281A for e-chains®** (not for e-tubes) with an 12-mm base, for combinations between spacers of different widths and vertical separators in side-mounted applications, for instance.

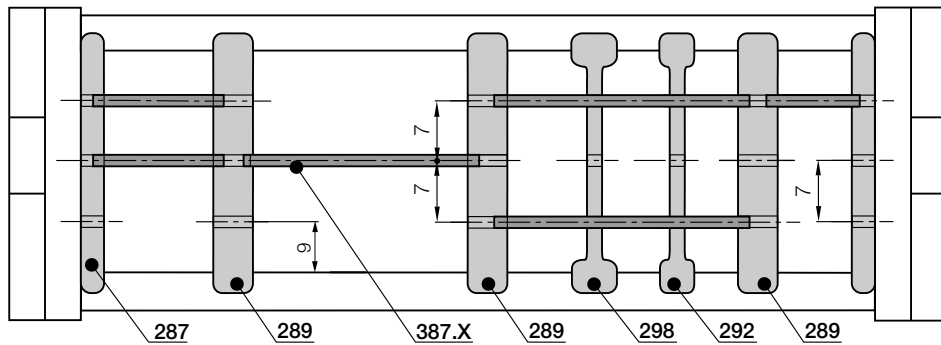

For use with many cables of differing diameters. e-chains® and e-tubes can be subdivided both vertically and horizontally. The shelves can be arranged elevator-shifted with different bottoms

### Option 2: Shelves

● Side plates 286, middle plates 288 und shelves 386.X form the basic pattern of a shelf system. Shelves of various widths can be arranged at 3 different heights (in 7 mm increments).

● For special applications: Vertical separator with injection moulded shelf 281.S.57 (57,5 mm) or 281.S.45 (45 mm).

● Slotted separators 291 (not for e-tubes), are used for very fine subdivisions. However, they cannot be retrofitted into an existing separation system without dismantling the interior separators first.

● The unilateral open, slotted separator 297 can be retrofitted into an existing interior separation system without a need for dismantling the interior separators. During an installation of open slotted separators, the top and bottom notches cannot be occupied by shelves.

Diagram	Part Name	unassembled	assembled
	Side plate for e-chains®/e-tubes	286	287
	Middle plate for e-chains®/e-tubes	288	289
	Vertical separator for e-chains®/e-tubes	281.S.57	282.S.57
	Vertical separator for e-chains®/e-tubes	281.S.45	282.S.45
	Slotted separator for e-chains®	291	292
	Open slotted separator for e-chains®/e-tubes	297	298

Width X [mm]	Part No. unassembled	Part No. assembled
018	386.18	387.18
023	386.23	387.23
025	386.25	387.25
028	386.28	387.28
033	386.33	387.33
043	386.43	387.43
050	386.50	387.50
054	386.54	387.54
062	386.62	387.62
075	386.75	387.75

Width X [mm]	Part No. unassembled	Part No. assembled
087	386.87	387.87
100	386.100	387.100
108	386.108	387.108
125	386.125	387.125
150	386.150	387.150
175	386.175	387.175
200	386.200	387.200
208	386.208	387.208
225	386.225	387.225

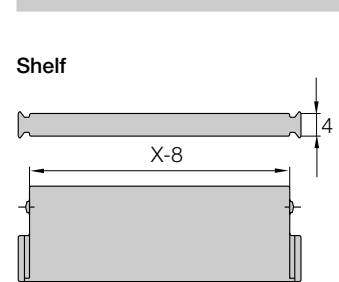
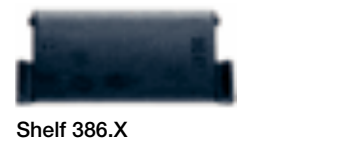
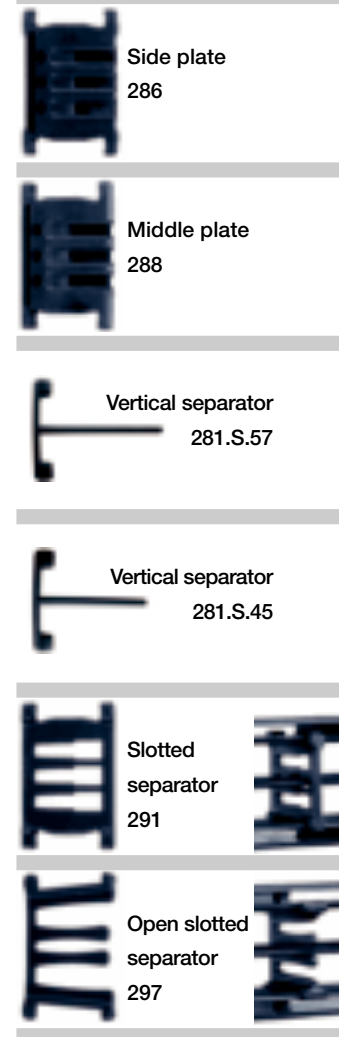

System E4/00  
Inner height: 32 mm

Phone +49- (0) 22 03-96 49-800  
Fax +49- (0) 22 03-96 49-222

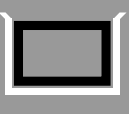
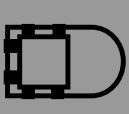



### Extension links - for extremely wide e-chains® up to 3,0 m

- For applications in which particularly high fill weights necessitate extremely wide e-chains® (up to 3000 mm)
- The extension link design allows virtually limitless side-by-side attachment of chains
- The unsupported length of a chain can be increased when additional loads are required
- Extension links can be used with e-chains®, e-tubes or as a combination of both
- They are suitable for unsupported and gliding applications in a guide trough
- e-chains® with extension links are attached with KMA or steel mounting brackets



Part No. structure  
280.10 /20 /10. 200 .0  
280.Bi1/Bi2/Bi3. R .0

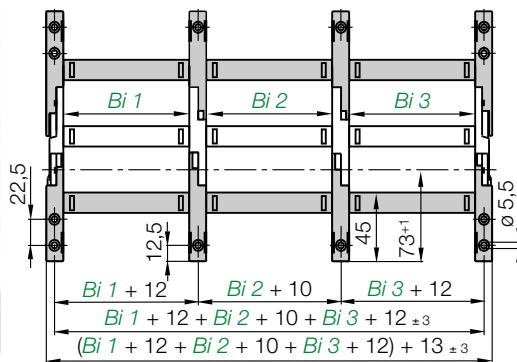
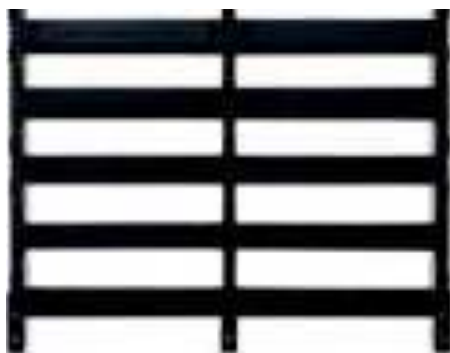

### Extender crossbars - careful guide of hoses applications

- Suitable for hoses with a maximum outer diameter of 105 mm
- Gliding operation with crossbars assembled along the outer radius and a special guide trough
- Gliding operation not guaranteed with crossbars assembled along the inner radius
- The extender crossbar can either be attached to the side links directly or can be used in combination with two stranded snap-open crossbars

Consult igus® for your extender crossbar applications. We are happy to assist you with your design layout

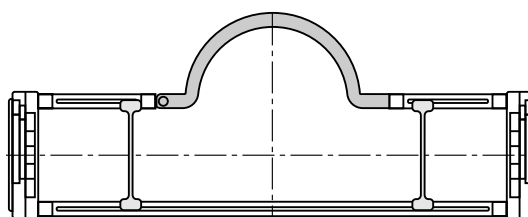

385.15RHD115 round extender crossbar combined with snap-open crossbars

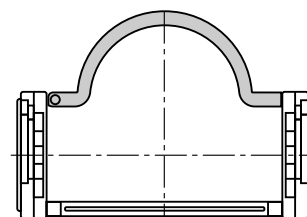

385.18RD115 round strap attached directly on the side link

Part No.	Max Ø [mm] hose	Form	Installation side link	Combination with snap-open crossb.
385.15.RHD115	105	○	-	+
385.18.RD115	105	○	+	-

○ = round + = yes / - = no



### Hinged crossbars

- Typically e-chain® crossbars are completely removable. In cases where the snap-open crossbars have to remain at the open link of the e-chain®, a hinged design has been developed
- Length: 37,5 mm **Part No. 385.02** / snap-open crossbar (shortened): *Bi*-37,5 mm **Part No. 385.03**
- Please consult igus® for design assistance

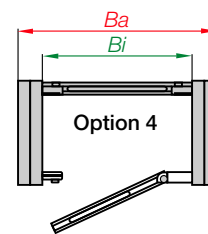
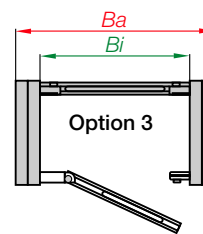
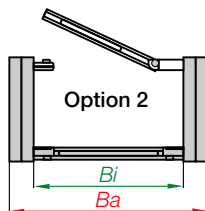
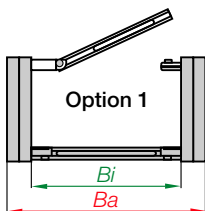
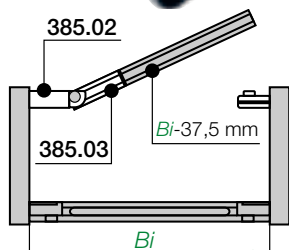

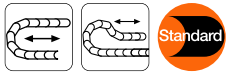

### The Standard - Option KMA\* - pivoting

- Recommended for unsupported and gliding applications
- Confined installation conditions
- Option - integrated C-profile strain relief device with chainfix clip or strain relief tiwrap plates
- Corrosion resistant
- Universally mountable with attachment capability on all sides

\*KMA = Polymer Metal Mounting Bracket

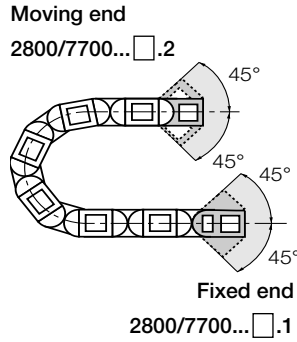

The attachment variants arising automatically by the choice of the KMA mounting bracket

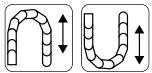
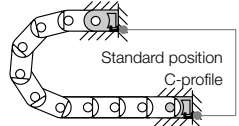

### Option KMA - locking

- Recommended for vertical hanging / standing applications

Additionally:

- Universally mountable
- C-profile option
- Corrosion resistant
- Locked connections
- At very high acceleration

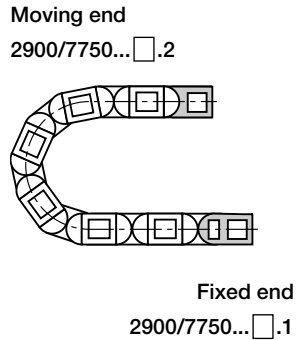

The attachment variants arising automatically by the choice of the KMA mounting bracket

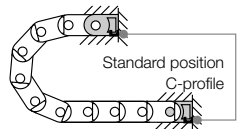

Fixed end  
2800/7700...□.1 (pivoting)  
2900/7750...□.1 (locking)

Moving end  
(pivoting) 2800/7700...□.2  
(locking) 2900/7750...□.2

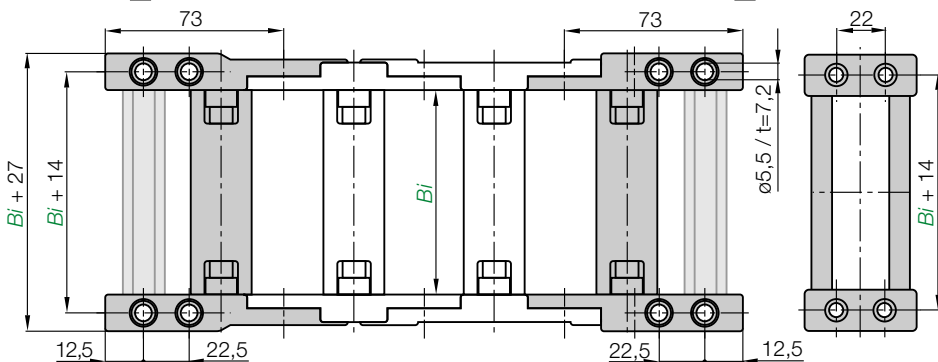

Width index	Part No. full set pivoting	Part No. full set locking	C-profile option [mm]	Width index	Part No. full set pivoting	Part No. full set locking	C-profile option [mm]
.05.	2800/7700	2900/7750	.05. □.12.□ 50	.23.	2800	2900	.23. □.12.□ 225
.06.	2800	2900	.06. □.12.□ 68	.237.	2800	2900	.237. □.12.□ 237
.07.	2800/7700	2900/7750	.07. □.12.□ 75	.25.	2800/7700	2900/7750	.25. □.12.□ 250
.087.	2800	2900	.087. □.12.□ 87	.262.	2800	2900	.262. □.12.□ 262
.10.	2800/7700	2900/7750	.10. □.12.□ 100	.28.	2800	2900	.28. □.12.□ 275
.11.	2800/7700	2900/7750	.11. □.12.□ 108	.29.	2800	2900	.29. □.12.□ 287
.112.	2800	2900	.112. □.12.□ 112	.30.	2800/7700	2900/7750	.30. □.12.□ 300
.12.	2800/7700	2900/7750	.12. □.12.□ 125	.312.	2800	2900	.312. □.12.□ 312
.137.	2800	2900	.137. □.12.□ 137	.325.	2800	2900	.325. □.12.□ 325
.15.	2800/7700	2900/7750	.15. □.12.□ 150	.337.	2800	2900	.337. □.12.□ 337
.162.	2800	2900	.162. □.12.□ 162	.350.	2800	2900	.350. □.12.□ 350
.17.	2800/7700	2900/7750	.17. □.12.□ 168	.362.	2800	2900	.362. □.12.□ 362
.18.	2800	2900	.18. □.12.□ 175	.375.	2800	2900	.375. □.12.□ 375
.187.	2800	2900	.187. □.12.□ 187	.387.	2800	2900	.387. □.12.□ 387
.20.	2800/7700	2900/7750	.20. □.12.□ 200	.400.	2800	2900	.400. □.12.□ 400
.212.	2800	2900	.212. □.12.□ 212				

Please insert **1** for odd number of links or **2** for even number of links

### Dimensions and order configurations

Part No. structure (pivoting)

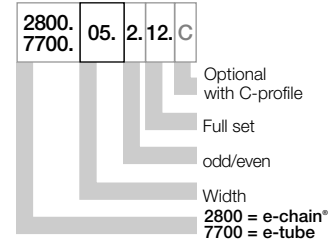

Part No. structure (locking)

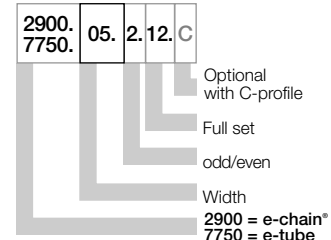

**Note:** The E4/00 System may end with either an inner side or an outer side link. Keep in mind that an outer side link always forms the first chain link at the moving end. The Part No. depends on an even or odd numbers of links. Please insert: **1** for odd number of links or **2** for even number of links

Full set, for both ends:

2900. 05. 2. 12. □ C (even)

Single-part order:

2900. 05. 2. 2. □ C (even)

Mounting bracket moving end

2900. 05. 2. 1. □ C (even)

Mounting bracket fixed end

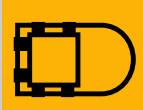





igus® chainfix steel clamps and chainfix stainless-steel clamps - max. pull forces, adjustable with hexagon socket. Available as single, double or triple clamps.

Details ► chapter 10

### chainfix clamps for the C-profile

Part No. single clamps		Part No. double clamps		Part No. triple clamps		Cable ø [mm]
steel	stainless steel	steel	stainless steel	steel	stainless steel	
CFX12.1	CFX12.1.E	CFX12.2	CFX12.2.E	CFX12.3	-	06 - 12
CFX14.1	CFX14.1.E	CFX14.2	CFX14.2.E	CFX14.3	-	12 - 14
CFX16.1	CFX16.1.E	CFX16.2	CFX16.2.E	CFX16.3	-	14 - 16
CFX18.1	CFX18.1.E	CFX18.2	CFX18.2.E	CFX18.3	-	16 - 18
CFX20.1	CFX20.1.E	CFX20.2	CFX20.2.E	CFX20.3	-	18 - 20
CFX22.1	CFX22.1.E	CFX22.2	CFX22.2.E	CFX22.3	-	20 - 22
CFX26.1	CFX26.1.E	CFX26.2	CFX26.2.E	-	-	22 - 26
CFX30.1	CFX30.1.E	CFX30.2	CFX30.2.E	-	-	26 - 30
CFX34.1	CFX34.1.E	CFX34.2	CFX34.2.E	-	-	30 - 34
CFX38.1	CFX38.1.E	-	-	-	-	34 - 38
CFX42.1	CFX42.1.E	-	-	-	-	38 - 42



### chainfix Clip - Modular snap-on strain relief device for C-profile

Available for all igus® e-chainsystems® with C-profiles and also suitable for assembly in the KMA mounting brackets and clip-on strain relief for crossbars. High pull forces, plug-in modular snap-on strain relief device. Details ► chapter 10

Cable ø [mm]	Part No. clamp	Part No. bottom part
04 - 08	CFC-08-M	CFC-08-C
08 - 12	CFC-12-M	CFC-12-C
12 - 16	CFC-16-M	CFC-16-C
16 - 20	CFC-20-M	CFC-20-C
20 - 24	CFC-24-M	CFC-24-C



### chainfix Nugget for the C-Profile

Strain relief for the fixation of cables up to a diameter of Ø 30 mm. Easy to assemble, without any screws and tools. Easy strain relief due to fixation with pre-harnessed cable strap, very small space requirement.

Details ► chapter 10

Part No.	ø max. conduit [mm]	Width [mm]
CFN.20	20	10,8
CFN.30.52*	30	16,4
CFN.20.N35*	20	20,0

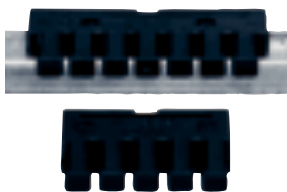

### chainfix tiwrap plates with clip-on connection for the C-profile

Can be plugged into the KMA C-profile. Easy to assemble without any screws. Easily solvable with screwdriver nevertheless safe stop. For all e-chains® with KMA and integrated C-profile. Details ► chapter 10

Part No.	Width of strain relief [mm]	Number of teeth
3050.ZC	50	5
3075.ZC	75	7



### Tiwrap plate as individual part

As individual component screwed on KMA. Can be plugged in the mounting brackets. Details ► chapter 10

Tiwrap plate	No. of teeth n	Dim. C [mm]	Dim. B [mm]	Center bore
3050.ZB	5	50	30	-
3075.ZB	7	75	55	-
3100.ZB	10	100	80	-
3115.ZB	11	115	95	-
3125.ZB	12	125	105	-
3150.ZB	15	150	130	-
3175.ZB	17	175	155	-
3200.ZB	20	200	180	+
3225.ZB	22	225	205	+
3250.ZB	25	250	230	+

(- = no / + = yes)

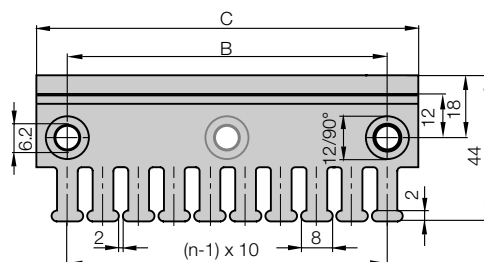
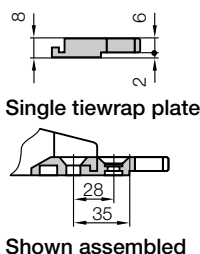

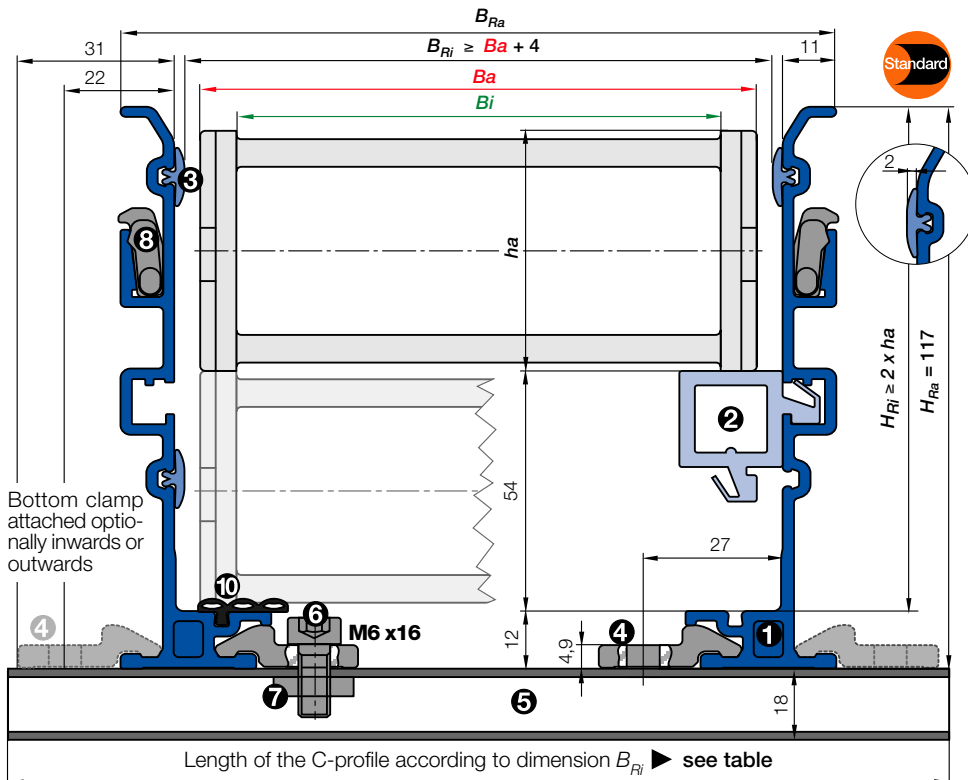

- $B_a$  = Outer width e-chains® / e-tube
- $B_i$  = Inner width e-chains® / e-tube
- $h_a$  = Outer height e-chains® / e-tube
- $H_{Ri}$  = Inner trough height
- $H_{Ra}$  = Outer trough height
- $B_{Ri}$  = Inner trough width ▶ depends on dim.  $B_a$
- $B_{Ra}$  = Outer trough width
- $n_{Mon}$  = Number of installation sets (left/right)
- $n_{Ri}$  = Number of trough sets (left/right)
- !  $H_{Ri} \geq 2 \cdot h_a$
- !  $B_{Ri} \geq B_a + 4$
- = Guide trough set    ● = Glide bar
- = Installation set "Basic"    ● = C-profile

**Installation set "Basic" with C-profile**

Bottom Clamp attached optionally inwards or outwards

280.05.200.0 ▶ Order example

$B_{Ri}$ [mm]	Part No. attached inwards	Part No. attached outwards	
			.05
.06	95	960.30.150	960.30.200
.07	102	960.30.150	960.30.200
.087	114	960.30.175	960.30.225
.10	127	960.30.175	960.30.225
.11	135	960.30.200	960.30.250
.112	140	960.30.200	960.30.250
.12	152	960.30.200	960.30.250
.137	165	960.30.225	960.30.275
.15	177	960.30.225	960.30.275
.162	190	960.30.250	960.30.300
.17	195	960.30.250	960.30.300
.18	202	960.30.250	960.30.300
.187	215	960.30.275	960.30.325
.20	227	960.30.275	960.30.325
.212	240	960.30.300	960.30.350
.23	252	960.30.300	960.30.350
.237	265	960.30.325	960.30.375
.25	277	960.30.325	960.30.375
.262	290	960.30.350	960.30.400
.28	302	960.30.350	960.30.400
.29	315	960.30.375	960.30.425
.30	327	960.30.375	960.30.425
.312	340	960.30.400	960.30.450
.325	352	960.30.400	960.30.450
.337	365	960.30.425	960.30.475
.350	377	960.30.425	960.30.475
.362	390	960.30.450	960.30.500
.375	402	960.30.450	960.30.500
.387	415	960.30.475	960.30.525
.400	427	960.30.475	960.30.525



- **Components, trough "Basic":** ① Trough side parts, aluminum, 2 m ② Glide bar, plastic, 2 m ③ Glide strips, plastic, 2 m (without glide strips on request) ⑩ Optional: Silencer profile, rubber
- **Components, installation set "Basic":** ④ Bottom clamp, aluminum ⑤ C-profile, steel galvanized ⑥ Screw M6 x16 ⑦ Sliding nut M6 ⑧ Interface connector, plastic

**Order example: Length of travel 30 m - Center mounted for Series 280.30.300.0 with  $B_{Ri} = 327$**

- Guide trough set (set of 2 trough side parts, incl. glide strips) **without** glide bar  
Order text: 16 m guide trough without glide bar (8 x 2 m sections)    Part No.    972.30.SL
- Guide trough set (set of 2 trough side parts, incl. glide strips) **with** glide bar  
Order text: 16 m guide trough with glide bar (8 x 2 m sections)    Part No.    972.31.SL
- Installation set "Basic" complete (guide trough-sets + 1)  
Order text: 17 installation sets "Basic"    Part No.    960.30.375
- Module for the fixed end  
Order text: 1 set    Part No.    972.80
- Option: For an additional noise dampening with silencer profile, please add Index A - Example:    Part No.    972.30.SLA

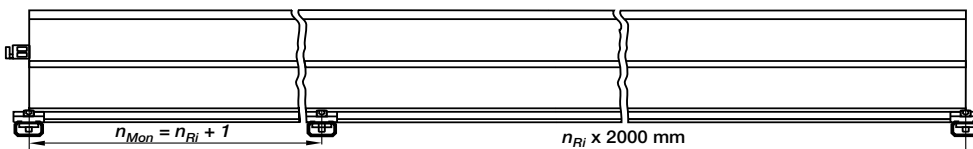

Principle sketch: Number of installation sets to be installed = **Number of trough sections + 1**



**A quick fix for mounting the stationary end of an e-chain®**

With this module for the fixed end, fast and easy mounting onto the Aluminum "SuperTrough" is now possible without any drilling. Fast mounting of the e-chain® by clamping onto the aluminum trough

- Quick relocation of the stationary end
- No drilling necessary ▶ page 9.16

Insert for the installation set "Heavy-Duty": **972.50.XXX** instead of (960.30.XXX) on the right column "attached outwards"

Phone +49- (0) 22 03-96 49-800  
Fax +49- (0) 22 03-96 49-222

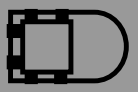

▶ chapter 10



▶ chapter 9



▶ page 7.255